

Technical Data

Brodie AddPak Additive Injection Block

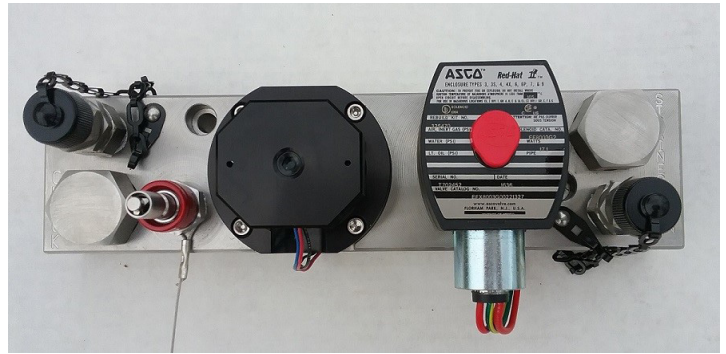

General

Brodie [Model Code] Chemical Injector offers a wide variety of service options. Due to its complete stainless steel construction and elastomer selection, it is suitable for use in numerous chemical and industrial applications. The Injector is machined out of a solid piece of stainless steel bar stock which minimizes external leak points, and also incorporates an inlet machined basket strainer and an outlet check valve.

Installation

The Injector's slim footprint allows for easy installation with minimal space requirements. The [Model Code] Chemical Injector easily incorporates into numerous applications from PLC to TAS Systems used as a slave injector.

Mechanical

Available in 1-6 Pack Configuration
303 Stainless Steel Machined Block
Inlet & Outlet Isolation Valves
Calibration Port Valved with Dust Cap
Elastomers Wetted are all Teflon or Teflon Encapsulated Material
Optional Elastomer Material: Kalrez or Chemrez Seals per Request
Flow Range .05 - 3 GPM
Oval Gear Meter K Factor: Available Full and Half-Height Gears
2500 PPG Norm 5200 PPG Extended

Electrical

ASCO Explosion Proof Solenoid
120VAC 60HZ Standard, Other Voltage Available per Request
Oval Gear Meter Sensor 5 - 30 VDC, Supply Hall-Effect or Reed Switch
Open Collector High Speed
Suitable for Hazardous Area
UL/CUL Approvals for use in Class I, DIV I Areas

Oval Gear Meter

The Injector's oval gear meter design allows for wide chemical use in additives and marker applications. Due to product design, the oval gears are able to achieve a very accurate measurement in single c/c units.

Approvals

Meets approvals for use in hazardous locations per UL and Cenelec.

For Optional Accessories Listed Below, Please Contact Factory:

- Standard & Dye Injection Point Kits
 - Calibration Kits
 - Injector Thermal Relief Kits
 - Special Elasmers
 - Special Approvals
-

Technical configuration

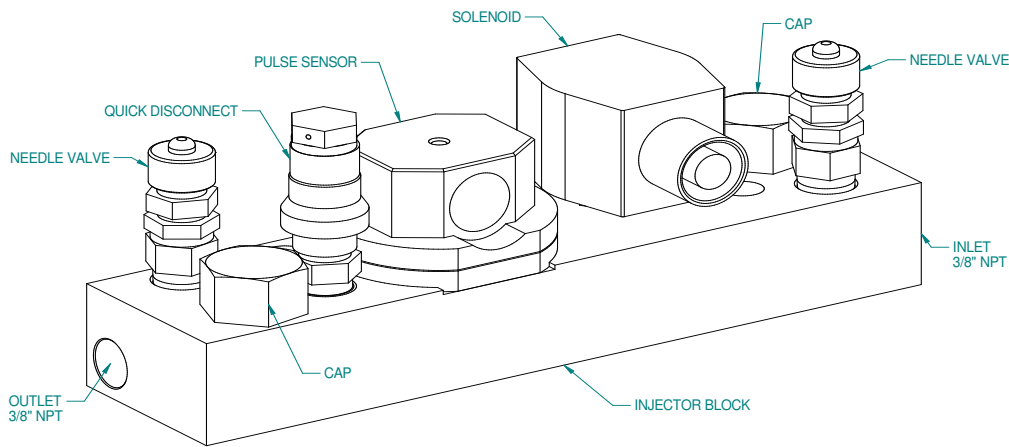

Brodie International

P.O. Box 450 (30459-0450)
19267 Highway 301 North
Statesboro, GA 30461
USA

Phone: +1 (912) 489-0200
Fax: +1 (912) 489-0294