

Product Datasheet

DAN-LIQ-Control Valve 788-DS-0807

August 2007

Liquid Control Valves

**Daniel® Model 788
Digital Control Valve**

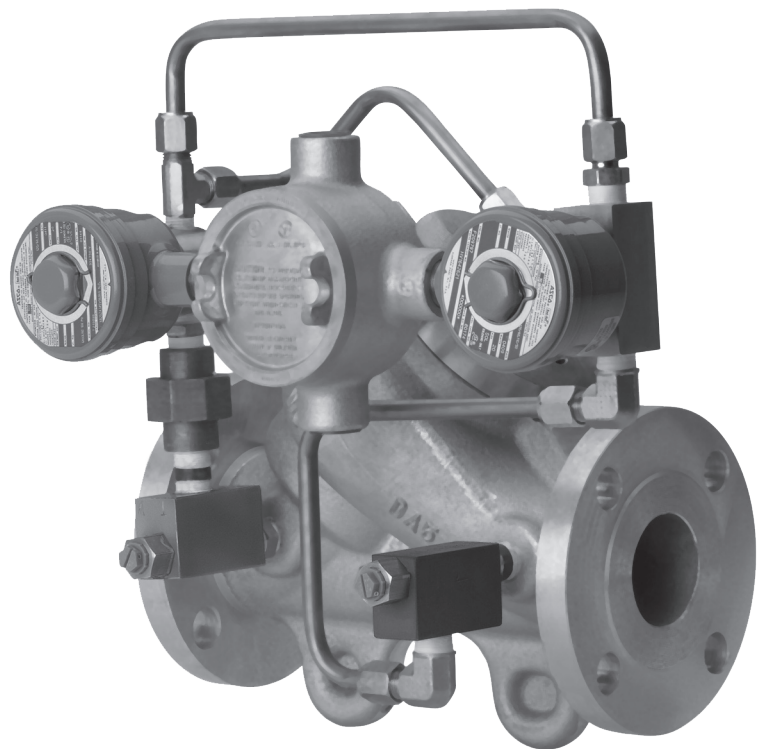

DANIEL®
www.daniel.com

EMERSON™
Process Management

Product Datasheet

DAN-LIQ-DS-788-0807

August 2007

Daniel® Model 788 Digital Control Valve

The Daniel Model 788 Digital Control Valve is designed to provide precise flow rate control and batch delivery of fluid products when used with an electronic batch control device (preset).

The Daniel Model 788 Digital Control Valve is automatically controlled by the preset for low flow start-up, high flow rate control, low flow shutdown, and final shut off. This valve also provides for maximum flowmeter accuracy by maintaining a constant flow rate with varying line pressures. The Daniel Model 788 Digital Control Valve features an external pilot control loop that consists of a normally open solenoid pilot, a normally closed solenoid pilot, strainer and opening/closing controls.

Applications:

The Daniel Model 788 Digital Control Valve can be used in any application requiring precise flow rate control with batch capability when used with an electronic preset capable of digital valve control including loading and off-loading (truck, railcar, ship, barge, etc).

Features and Benefits:

- Precise flow rate and batch control
- Modular construction -- All internal parts including seat and seat ring may be removed as a cartridge assembly without the need to remove the valve body from the system piping.
- No diaphragms or stuffing boxes
- 45° body design assures high capacity and low pressure drop
- Positive (bubble tight to Class VI) shut-off
- Linear control characteristics with uniform response speed
- Fail-safe closure on loss of power
- Aggressive Products (AP) Option with Teflon® elastomers

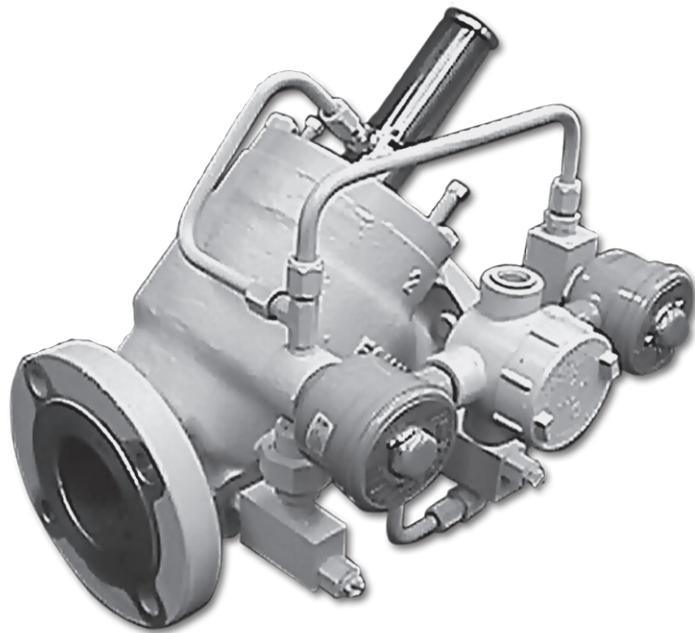

Product Datasheet

DAN-LIQ-DS-788-0807

August 2007

Specifications:

Please consult Daniel if your requirements are outside the specifications noted below. Improved performance and other product and material offerings may be available depending on the application. For world area locations and contact information, refer to the back page of the data sheet.

Flange Connections / Ratings (ANSI):

Valve Size	150 lbs. ANSI MWP at 38°C	300 lbs. ANSI MWP at 38°C
2" - 8"	285 psi	740 psi

Flange Connections / Ratings (DIN):

Valve Size	DIN PN16 MWP at 38°C	DIN PN25 MWP at 38°C	DIN PN40 MWP at 38°C	DIN PN64 MWP at 38°C
DN50 - DN300	16 bar	25 bar	40 bar	51 bar

MWP: Maximum Working Pressure

Temperature Range*:

-20°F to 150°F (-29°C to 66°C)

Optional 250°F (121°C)

* **Subject to material specifications**

Valve Capacity:

Valve Size	2"	3"	4"	6"	8"
Cv (GPM)	86	186	309	688	1,296

Documentation and Approvals:

- UL and CSA Listed
- Class I - Groups C & D
- Class II - Groups E, F & G
- Explosion Proof Nema Types 7C, 7D, 9E, 9F, 9G and waterproof Nema type 4
- CE (ATEX, PED [or SEP] and EMR)
- ATEX II 2G/D EEx d IIC T6-T4

Maximum Operating Pressure Differential (MOPD) Across Pilots:

150 lb. Standard - 150 psid (1,035 kPa)

Optional - 285 psid (1,967 kPa)

300 lb. Standard - 740 psid (5,106 kPa)

Product Datasheet

DAN-LIQ-DS-788-0807

August 2007

Materials of Construction:

Main Valve Body: Steel - ASTM-A352-GR-LCC

Main Valve Cylinder: 2" - 4" Stainless Steel Heat Treated
17-4 pH
6" - 8" Carbon Steel, Nickel Coated

Main Valve Piston: 2" - 8" 304 Stainless Steel

Seat Ring: 2" - 6" 304 Stainless Steel
8" Carbon Steel, Nickel Coated

O-Rings: Standard - Viton®
Optional - Available in Neoprene, EPR, Kalrez®,
Teflon® ("AP" Valves)

Other Internal Parts: Stainless Steel

Pilot Valve / Strainer / Needle Valve Trim: Stainless Steel

Pilot O-rings: Viton®, Kalrez® or Teflon®

Tubing and Fittings: Standard - Steel
Optional - Stainless Steel

Standard Equipment:

- Pre-wired solenoids (optional for CE execution)
- Opening and closing speed controls
- Self-cleaning strainer (pilot inlet)
- Stainless steel solenoid pilots
- Steel tubing and fittings

Optional Equipment:

- Pre-wiring for valves with CE solenoids
- Manual override
- Valve position indicator
- Thermal relief
- Stainless steel tubing and fittings

Aggressive Products Option:

The use of aggressive additives or oxygenates call for the Aggressive Products, or AP option. The AP option valve cylinder incorporates cup-seals (Teflon® Bal Seals) and an O-ring made from appropriate materials for such challenging conditions. Materials for pilots such as low swell nitrile (main valve static O-rings) and Kalrez® or Teflon® are available.

Approximate Shipping Weight and Volume

Valve Size	150 lbs.				300 lbs.			
	Shipping Weights		Shipping Volume		Shipping Weights		Shipping Volume	
	lbs.	Kgs.	Cubic Feet	Cubic Meters	lbs.	Kgs.	Cubic Feet	Cubic Meters
2"	60	27	1.7	.047	65	29	1.8	.050
3"	105	48	2.4	.067	115	52	2.5	.070
4"	140	64	2.5	.071	165	75	3.1	.087
6"	250	114	4.9	.137	290	132	6.0	.169
8"	400	181	8.9	.253	465	212	10.0	.283

Product Datasheet

DAN-LIQ-DS-788-0807

August 2007

No indicator

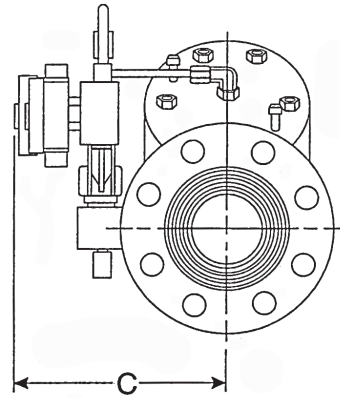
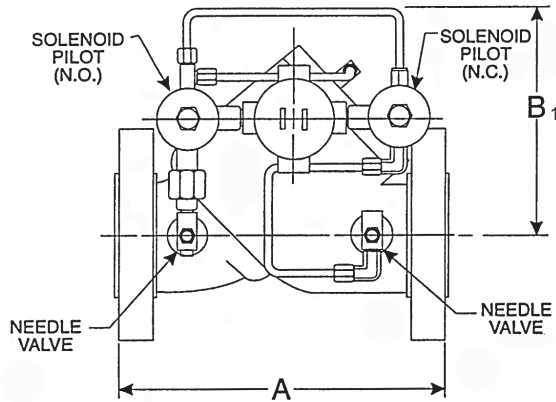

With indicator

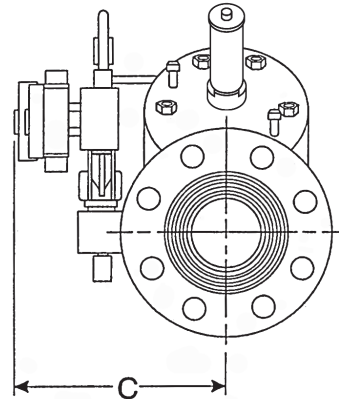
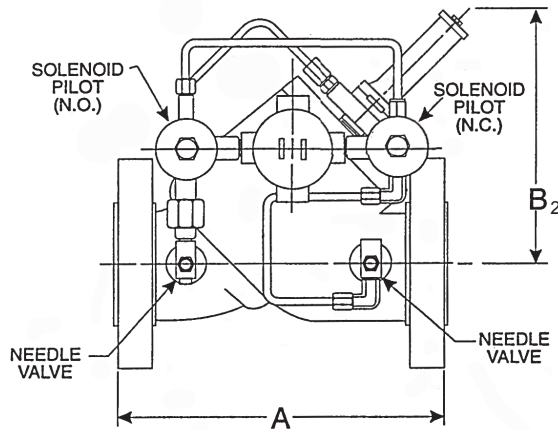

Valve Size	A	B ₁ No Indicator	B ₂ With Indicator	C
2"	10.25"	9"	11"	8.25"
	260 mm	229 mm	279 mm	210 mm
3"	11"	9"	12"	8.75"
	279 mm	229 mm	305 mm	222 mm
4"	13"	9"	12.5"	9"
	330 mm	229 mm	318 mm	229 mm
6"	17"	12"	15.75"	11"
	432 mm	305 mm	400 mm	279 mm
8"	22.25"	15"	17.5"	11.75"
	565 mm	381 mm	445 mm	298 mm

Product Datasheet

DAN-LIQ-DS-788-0807

August 2007

Operational Sequence*

With both solenoids de-energized, the main valve is closed. The main valve can be infinitely positioned anywhere between 0-100% open by digital control of the solenoids. With both solenoids energized, as shown in Figure 2, the valve begins to open. It will only open to the programmed flow rate set in the preset. Normally, the preset is programmed to digitally control low flow start-up rate, maximum flow rate, low flow rate before shut-off and final shut-off. The preset will automatically energize and de-energize the solenoids to position the main valve to attain the required flow rate. When the required rates are reached the solenoids will be as shown in Figure 3. This hydraulically locks the main valve piston in position. Should flow increase, the valve will close slightly to adjust to the required rate. All of the positioning is done by digitally controlling the two solenoids as shown in Figures 1,2 and 3. The valve opening and closing speeds can be adjusted independently via the two needle valves which are shown below.

Figure 1 Closed or Closing Position

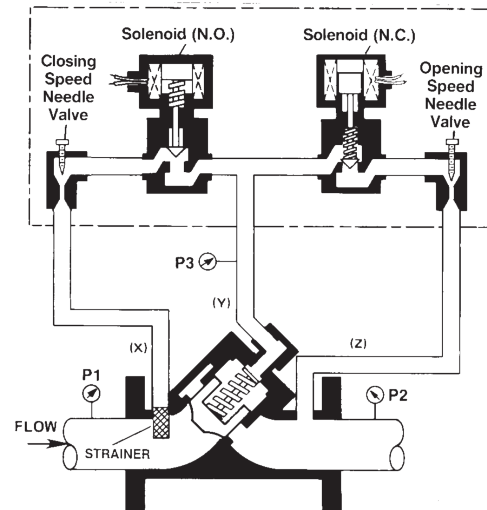

Closed or Closing Position - The normally closed solenoid is closed. The normally open solenoid is open. Y-Port (P3) to Z-port (P2) is closed. X-port (P1) and Y-port (P3) pressures are balanced. The main valve spring, being the differential force, closes the piston and keeps it seated.

Figure 2 Full Open / No Control

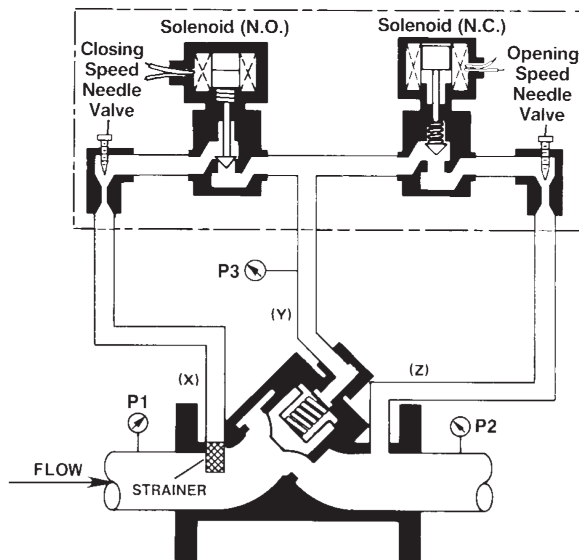

Opening Position - The normally closed solenoid is open. The normally open solenoid is closed. Y-Port (P3) is open to Z-port (P2). X-port (P1) is closed off by the normally open solenoid. The pressure on the bottom of the piston (P1) is greater than the pressure at (P3) plus the spring force; (P1 minus P2) is equal to or greater than the spring force. Therefore, (P1) pressure pushes the piston open.

Figure 3 Controlling Position

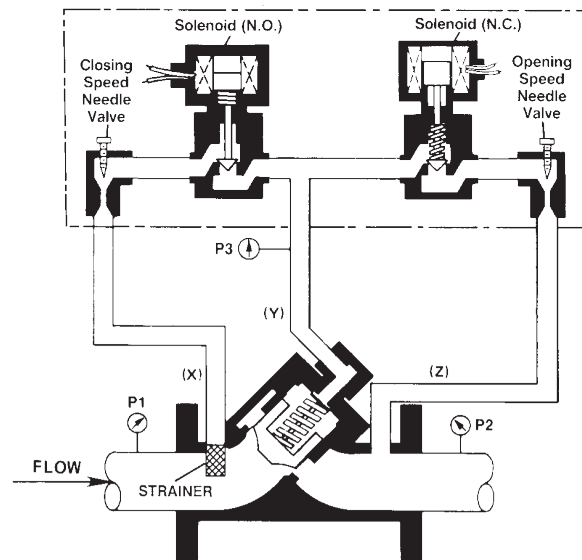

Controlling Position - The normally closed solenoid is closed. The normally open solenoid is closed. Y-Port (P3) to Z-port (P2) is closed. X-port (P1) to Y-port (P3) is closed. Note: The product cannot flow to or from the top of the piston (Y-port). The piston is hydraulically locked in position until the preset commands the valve to open or close as required to maintain the desired flow rate.

*Please refer to the Daniel Model 788 Digital Control Valve Operating and Maintenance Manual for all operating instructions and safety information.

Product Datasheet

DAN-LIQ-DS-788-0807

August 2007

Typical Applications

The most common application of the Daniel Model 788 Digital Control Valve is for truck loading. The figure below shows the Daniel Model 788 Digital Control Valve working with turbine meters and electronic preset to precisely control flow rates, batch quantities and blend ratio's of various products being loaded.

Load Rack Installation with Daniel® Model 788 Digital Control Valve for Ratio Blending

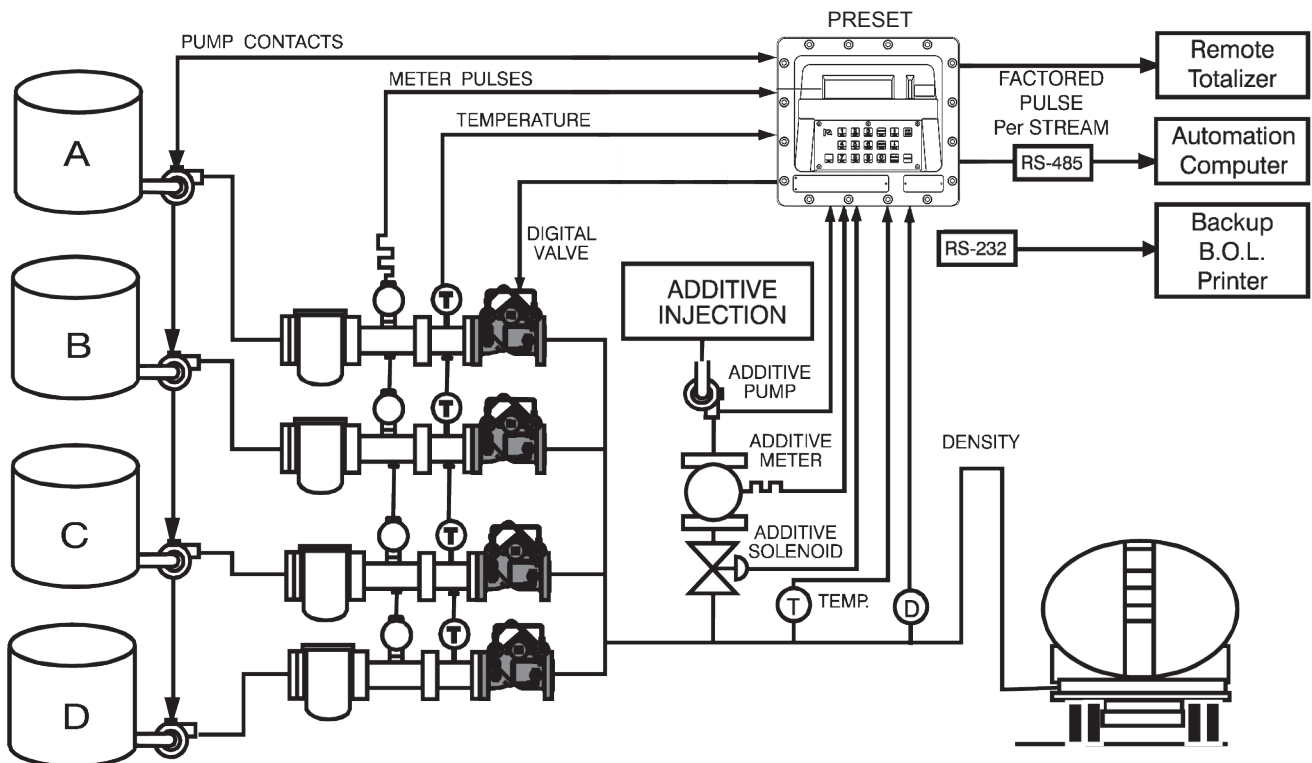

Product Datasheet

DAN-LIQ-DS-788-0807

August 2007

DANIEL® MODEL 788 DIGITAL CONTROL VALVE SELECTION MATRIX

CODE	DESCRIPTION		DN50	DN80	DN100	DN150	DN200	
V	VALVE BASE CODE		DN50	DN80	DN100	DN150	DN200	
	CODE	BASIC TYPE/PRIMARY FUNCTION	2"	3"	4"	6"	8"	
	788	Digital Control Valve Electrical Solenoid Pilot Control						
	CODE	REVISION LEVEL						
	A	INITIAL REVISION FOR 8" Valves						
	B	1998 REVISION FOR 2",3",4" & 6" Valves						
	CODE	SIZE						
	2	2" DN50						
	3	3" DN80						
	4	4" DN100						
	6	6" DN150						
	8	8" DN200						
	A	2" DN50 Low Flow Valve complete with 5° needle valve & V-profile cylinder ports						
	CODE	FLANGE RATING/MAXIMUM WORKING PRESSURE	2"	3"	4"	6"	8"	
	A	150 LB. ANSI / 285 PSI MWP (1,034 kPa) 150 PSI MOPD LIMIT						
	B	150 LB. ANSI / 285 PSI MWP (1,965 kPa) 285 PSI MOPD						
	C	300 LB. ANSI / 740 PSI MWP (5,102 kPa)						
	E	150 LB. RTJ ANSI / 285 PSI MWP (1,965 kPa)	CONTACT FACTORY					
	F	300 LB. RTJ ANSI / 740 PSI MWP (5,102 kPa)						
	H	PN16 DIN 2526 Form C / 16 Bars MWP 10.3 BAR MOPD LIMIT						
	J	PN16 DIN 2526 Form C / 16 Bars MWP						
	K	PN25 DIN 2526 Form C / 25 Bars MWP	N/A	N/A	N/A	N/A		
	L	PN 40 DIN 2526 Form C / 40 Bars MWP						
	R	150 LB. Replacement for 1815 120 PSI MOPD LIMIT	N/A			N/A	N/A	
	S	300 LB. Replacement for 1830 150 PSI MOPD LIMIT	N/A			N/A	N/A	

DANIEL® MODEL 788 DIGITAL CONTROL VALVE SELECTION MATRIX

CODE	MATERIALS OF CONSTRUCTION				2"	3"	4"	6"	8"
	Valve Body / Pilot Body	Piston	Tubing and Fittings						
E	CS / CS	SS	CS SAE						
F	CS / CS	SS	CS Metric						
G	CS / CS	SS	SS SAE						
H	CS / CS	SS	SS Metric						
M	Low Temp Steel	SS	SS SAE	CONTACT FACTORY					
N	Low Temp Steel	SS	SS Metric						
P	Nickel Coated / SS	SS	SS SAE						
Q	Nickel Coated / SS	SS	SS Metric						
R	CS / SS	SS	CS SAE						
S	CS / SS	SS	CS Metric						
T	CS / SS	SS	SS SAE						
W	CS / SS	SS	SS Metric						

Product Datasheet

DAN-LIQ-DS-788-0807

August 2007

CODE	ELASTOMERS	2"	3"	4"	6"	8"	
2	All Viton® (for 150 PSI MOPD use option P)						
3	All Viton® for LPG						
4	Main Valve: AP Model	788 Digital (150 PSI MOPD) 788 Digital (285/740 PSI MOPD)					Use option N
	Teflon® Dynamic/Low Swell Nitrile Static O-Rings Pilot: Kalrez® Dynamic/Low Swell						
	Nitrile Static O-rings						
5	Main Valve: AP Model	788 Digital (150 PSI MOPD) 788 Digital (285/740 PSI MOPD)					Use option N
	Teflon® Dynamic/Low Swell Nitrile Static O-Rings Pilot: All Kalrez® O-rings						
6	All EPR	CONTACT FACTORY					
7	All Neoprene						
8	All Nitrile						
9	AP Model Valve with All Teflon® Pilot O-rings.	788 Digital (MOPD: 135 PSI NC, 101 PSI NO)	Use option M				
A	Standard Valve with All Viton® for LPG O-rings	788 Digital (150 PSI MOPD)	Use option 3				
B	AP Model Valve with All Viton® Pilot O-rings.						
K	Standard Valve : Pilot with Teflon® Seats (120 PSI MOPD)	N/A	N/A	N/A	N/A	N/A	
L	AP Valve: Pilot with Teflon® Seats (120 PSI MOPD)	N/A	N/A	N/A	N/A	N/A	
M	Main Valve: AP Model	788 Digital (150 PSI MOPD)					
	Teflon® Dynamic/Low Swell Nitrile Static O-Rings Pilot: All Teflon® O-Rings						
N	AP Valve: Pilot- all Kalrez®	788 Digital (150 PSI MOPD)					
P	Standard Valve: Pilot- all Viton®	788 Digital (150 PSI MOPD)					
CODE	FIRST PILOT VARIABLE - VOLTAGE						
A	None						
	Voltage:						
1	6 Vdc					N/A	
2	12 Vdc						
3	24 Vdc						
4	48 Vdc						
5	110 Vdc					N/A	
6	110/120 Vac						
7	220/240 Vac						
8	440/480 Vac						

Product Datasheet

DAN-LIQ-DS-788-0807

August 2007

DANIEL® MODEL 788 DIGITAL CONTROL VALVE SELECTION MATRIX

CODE	SECOND FUNCTION									
A	NONE									
CODE	SECOND PILOT VARIABLE -SPRING RANGE OR VOLTAGE									
A	NONE									
CODE	OPTIONS									
	Thermal Relief	XYZ Block								
A	None	None								
C	X									
D		X								
Q	X	X								
CODE	OPTIONS			POSITION						
	Manual Override	Check Valve	Visual Indicator	Indicator w/1 switch	Indicat. w 2 switches	2"	3"	4"	6"	8"
A	None	None	None	None	None					
B	X									
C	X	X								
D	X		X							N/A
E	X			X						
F	X				X					
G	X	X	X							N/A
H	X	X		X						
J	X	X			X					
K		X								
M		X	X							
N		X		X						
P		X			X					
Q			X							N/A
R				X						
S					X					
T	Pos. indicator complete with guard and no switch									
CODE	APPROVALS									
A	None									
C	Material Test Reports					(Main valve pressure retaining parts only)				
D	NACE with Material Test Reports (MTRs)					(Main valve pressure retaining parts only)				
E	UL/CSA Certified Electric Component									
G	UL/CSA Certified Electric Component and MTRs					(Main valve pressure retaining parts only)				
H	UL/CSA Certified Electric Component and NACE with MTRs					(Main valve pressure retaining parts only)				
	CENELEC APPROVALS NO LONGER AVAILABLE									
3	CE (ATEX II 2G/D EEx em II T5-T3)									
4	CE (EEx em II) & MTRs									
5	CE (EEx em II) NACE + MTR's									
6	CE (ATEX II 2G/D EEx d IIC T6-T4)									
7	CE (EEx d II) & MTRs									
8	CE (EEx d II) NACE +& MTR's									

Product Datasheet

DAN-LIQ-DS-788-0807

August 2007

Ordering Information

When ordering, the following information must be supplied:

- Size
- Flange connections
- Product, product viscosity, product specific gravity
- Minimum and maximum operating temperature
- Minimum and maximum flow rate
- Minimum, normal and maximum operating pressure
- Control functions to be performed
- O-ring material
- Control pilot materials
- Tubing material
- Voltage required

Product Datasheet

DAN-LIQ-DS-788-0807

August 2007

Emerson Process Management
Daniel Measurement and Control, Inc.

World Area Headquarters
Houston, Texas, USA

T: 713-467-6000, F: 713-827-3880
USA Toll Free 1-888-FLOW-001
www.daniel.com

Calgary, Alberta, Canada
T: 403-279-1879, F: 403-236-1337

Singapore - Asia Pacific
T: +65-6777-8211, F: +65-6770-8001

Stirling, Scotland - Europe, Mid-East, Africa
T: +44 (0) 1786 433400, F: +44 (0) 1786 433401

Daniel Measurement and Control, Inc. ("Daniel") is a wholly owned subsidiary of Emerson Electric Co., and a division of Emerson Process Management. The Daniel name and logo are registered trademarks of Daniel Industries, Inc. The Emerson logo is a registered trademark and service mark of Emerson Electric Co. All other trademarks are the property of their respective companies. The contents of this publication are presented for informational purposes only, and while every effort has been made to ensure their accuracy, they are not to be construed as warranties or guarantees, expressed or implied, regarding the products or services described herein or their use or applicability. All sales are governed by Daniels' terms and conditions which are available upon request. We reserve the right to modify or improve the designs or specifications of such products at any time. Daniel does not assume responsibility for the selection, use or maintenance of any product. Responsibility for proper selection, use and maintenance of any Daniel product remains solely with the purchaser and end-user. The Daniel Model 788 Digital Control Valve is protected by U.S. and international patents and patents pending.

DANIEL[®]

EMERSON[™]
Process Management