

# MODEL HTP THERMOCOUPLE FOR SULFUR PLANTS FOR CLAUS THERMAL REACTORS AND SULFUR BURNING PROCESSES

TS HTP

## FEATURES

- Worldwide standard for protecting Claus reactors
- Remains accurate under extreme conditions
- Protects and extends the useful life of refractory and improves reactor up-time
- Over 25 years of proven results in hundreds of installations worldwide
- Keeps working accurately in sulfur service long after other thermocouple designs and infrared devices fail or read incorrectly
- Safe; triple sealed; block valve optional
- Accuracy is continuously verified
- Integral refractory dryout thermocouple reads accurately to 1°F (0.6°C)
- Worldwide service and parts capability
- Also used in process incinerators, POX units, and coal gasifiers
- Special designs to 10,000 PSIG (70 MPa) or 4000°F (2200°C)

## APPLICATION

The Type HTP Thermocouple is designed to measure high temperatures under the extremely severe conditions of a Claus Thermal Reactor. The atmospheres to be measured may contain hydrogen, sulfur, sulfur oxides, chlorides, acid gases, etc. Operating temperatures may be in excess of 3000°F and under pressure. Normal operating vibration will not cause sensor failure.

The most common application is to protect the refractory in Claus thermal reactors and sulfur burners in sulfur acid plants. Other applications include hydrogen burner systems, water gas generators, coal gasifiers and various kinds of POX units.

The design of the Model HTP is a result of careful attention to design detail, 25 years of experience, and many field installations. Materials used in the HTP are critical; for example, the ceramic parts exposed to the process are various blends of Alumina, Zirconia, MgO, and other materials. All conceivable care is taken during the application and fabrication of these units. The long service life and reliable operation of the HTP thermocouple sensor is a result of attention to detail.

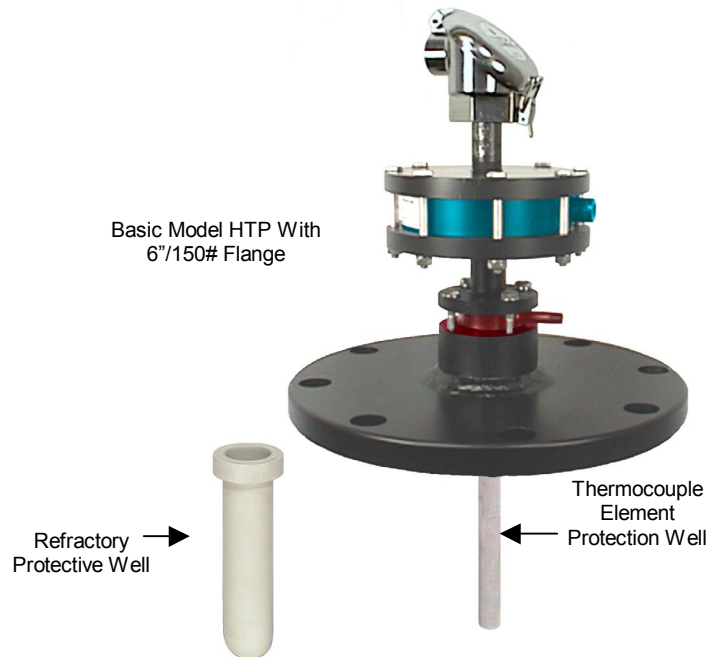

## SPECIFICATIONS

Thermocouple Types: B, R, C, & T (others available)  
Body/Flange Material: A-106B & A-105 Carbon Steel  
Trim, Bolting, and Seats: Stainless Steel  
Protective Well: Blended alumina ceramic  
Certification: C.S.A., NRTL/C (U.S. and Canada), GC (Europe)  
Mounting Flange: ANSI 6\"/150# (150mm) (Std.)  
Flush Gas: or clean, dry air.  
Working Pressure: 150 PSIG (1 MPa) at vessel skin temperature of 500°F (260°C)  
Working Temperature: 0 to 3100°F (1700°C) basic;  
0 to 4000°F (2200°C) optional.  
Auxiliaries: Nozzle insulation kit; refractory well; flush gas control system, installation tools

### Optional:

- Nozzle block valve for emergency shut-in
- 316L SS body, flange, and head housing
- Explosion proof head housing
- Thermocouple extension lead wire
- Refractory diamond drills and casting mandrels
- Infrared temperature transmitter; for use as a backup
- Field training and service

## TYPICAL LONG TERM USERS OF DELTA CONTROLS HTP THERMOCOUPLES

BP Amoco; Valero; Prichard; E.I. Dupont; Motiva Enterprises; Akzo Nobel; ADNOC; Reliance; Caribbean Petroleum; Exxon Mobil; Marathon Ashland; Pemex; Conoco Phillips; Eastman Chemicals; Clark Oil; Jupiter Sulfur; Xianan Pigment; Tosco Refining; Chevron Texaco; Chiyoda; Petrobras; Imperial; S.F. Phosphates; Shell; US DOE; Citgo; Total; CPC; Orion; PDVSA/Bariven, Unocal, and many others.

# DELTA CONTROLS CORP

## OPERATING SCHEMATIC OF THE HTP

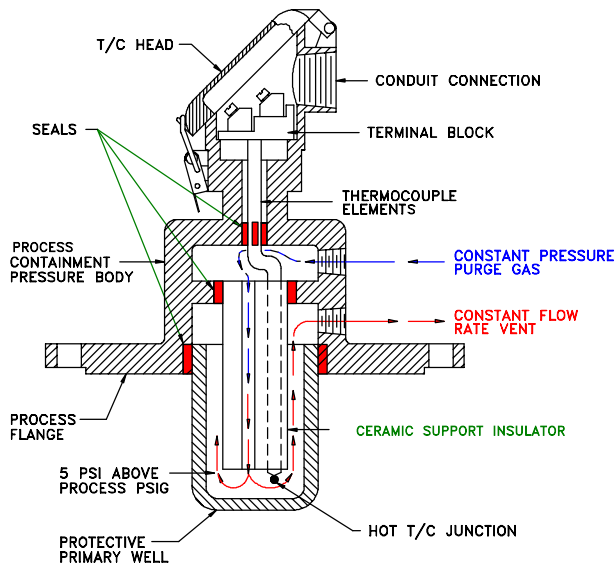

## HTP INSTALLED IN A CLAUS REACTOR

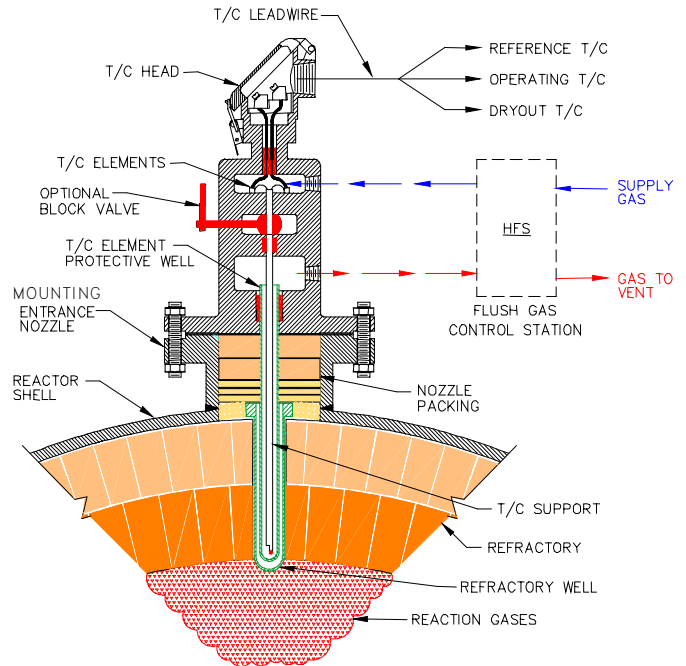

SCHMATIC REPRESENTATION  
- Shown with block valve -

Clean flush gas flows through the Model HTP and scavenges hydrogen, sulfur compounds, and corrosive gases that have penetrated or permeated the protective well. The flush gas flows into the upper chamber, down an annulus, over the hot junction, back up the protective well, and out through the vent connection. The flush gas must be clean and dry. The normal method of operation is to maintain a positive pressure inside the HTP. This pressure should be 3 to 5 PSI (28 kPa) above the maximum operating pressure of the reactor. This pressure is set by adjusting the control on the flush gas control station. The flow rate through the unit is set at 0.4 to 0.5 SCFH (190cc/m). This rate is controlled by the flush gas control station and does not significantly cool the T/C element.

## MODEL NUMBERING SYSTEM

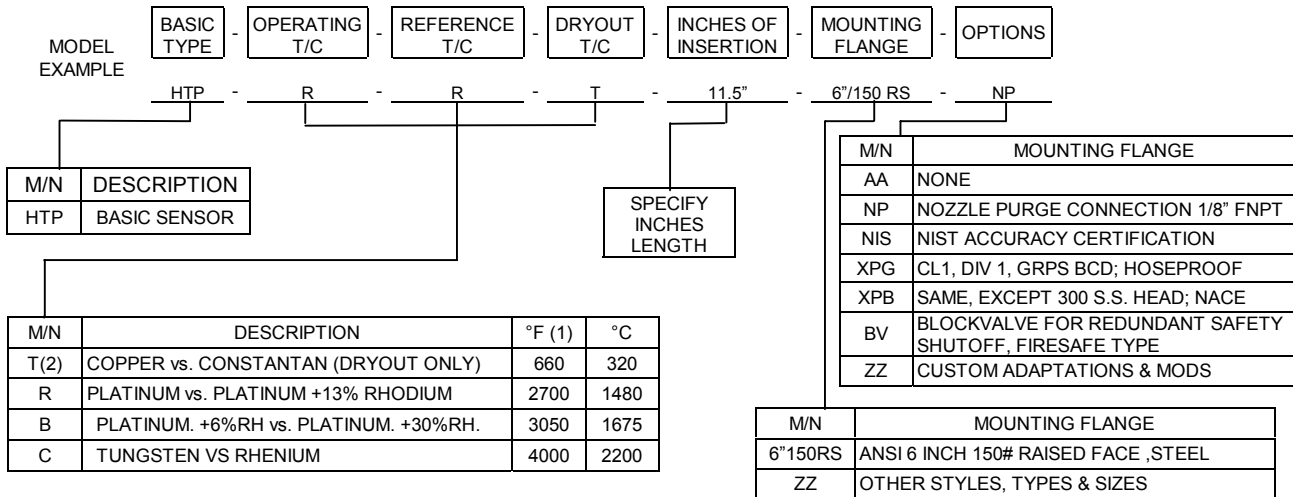

### NOTES:

- TEMPERATURE SHOWN IS THE MAXIMUM RECOMMENDED FOR CONTINUOUS SERVICE
- ACCURACY OF TYPE "T" DRYOUT T/C: ±0.9°F(0.5°C) OR BETTER AT 212°F(100°C); LIMITED TO 400°F(200°C) IN AIR; TO 660°F (320°C) IN NITROGEN

### AUXILIARY EQUIPMENT REQUIRED

M/N	DESCRIPTION - SEE SEPARATE DETAILED DATA SHEETS
HFS	FLUSH GAS CONTROL STATION, ZINC, SS TRIM OR ALL SS
H6G	DIAMOND BITS AND GUIDES TO DRILL A REFRACTORY HOLE
HRM	MANDREL FOR CASTING A HOLE THRU REFRACTORY
HRW	REFRACTORY PROTECTIVE WELL
HNP	REACTOR NOZZLE INSULATION PACKING KIT
HIR	SECONDARY TEMPERATURE SENSOR

**DELTA CONTROLS Corporation**  
Engineered Sensors – For Difficult Services

585 Fortson Street Shreveport, La. 71107  
Voice: (318) 424-8471 Fax: (318) 425-2421  
Email: delta@deltacnt.com Web: www.claustemp.com