



ALSONIC-EG

Ultrasonic Thermal Energy Meter Model Alsonic-EG

GENERAL

Alsonic-Energy meters feature transit-time ultrasonic flow measurement with two PT 100 temperature sensors or customer-supplied RTD sensors for calculating total and instantaneous energy consumption. Flow measurement may be achieved via clamp-on, spool piece, or insertion-type sensors. Our microprocessor based, user friendly field programmable flow measurement technique creates no interruption of the process flow and has low installation costs.

FEATURES

- Measures energy consumption rate and total
- Compact or wall mount version
- Proven ultrasonic technology for flow measurement and PT 100 for temperature
- Clamp-on, spool piece or insertion mounting for flow measurement
- Wide range velocities - 0.03 ~ ±105 feet/sec (0.01 ~ ±32 m/s)
- Transducers for pipe sizes ranging from ½" ~ 240" (15 ~ 6000 mm)
- Excellent accuracy - ±0.5% of reading.
- RS485 and Modbus communication protocols available
- 4-20 mA and pulse outputs with available relays and alarms
- Data logger function - includes time & date, totalizer, diagnostics
- Response time less than 1 second
- NIST traceable calibration certificate

SPECIFICATION

- | | | | |
|-------------------------|---|---------------------|--|
| ● Flow measurement | : Transit time ultrasonic method | ● Display | : LCD with t |
| ● Transducer type | : clamp-on, spool piece, or insertion | ● Keypad | : 4 x 4 tactile-feedback membrane keypad |
| ● Temperature measure | : Platinum 100 RTDs | | Displays energy rate, total consumption, temperature, instantaneous flow rate, accumulated flow rate, velocity, time |
| ● Pipe Size | : ½"-240" (25-6000mm) | ● Mounting | : wall mounting or integral |
| ● Pipe Material | : Cast Iron, Stainless Steel, Ductile Iron
Copper, PVC, Aluminum, Asbestos
Fiberglass... etc. | ● Max. Cable Length | : 500' (150 m) |
| ● Liner Material | : Tar Epoxy, Rubber, Mortar, Polypropylene,
Polystyryl, Ploystyrene, Polyester, Ebonite,
Polyethylene, Teflon... etc. | ● Power | : ≤ 2W |
| ● Flow Velocity | : 0.03 ~ ±105 feet/sec (0.01 ~ ±32 m/s) | ● Power Supply (AC) | : 90 ~ 260V _{AC} , 50/60 Hz |
| ● Resolution | : 0.0003 feet/sec (0.0001 m/s) | ● Power Supply (DC) | : 3.6V Li battery (for 6 years of operation) |
| ● Liquid temperature | : -40 ~ 312 °F (-40 ~ 155 °C) | ● Data Storage | : Totalized data up 64 days |
| ● Suspended solids | : <2%; particle size smaller than 75µm | | Time and corresponding flow rates of the last 64 times power on/off events |
| ● Engineering units | : Metric or English (US) | ● Signal outputs | : Manual or automatic flow loss consumption |
| Accuracy | : ± 1%-± 2% of reading from 1.5 - 100 feet/sec
± 0.5% of reading (online calibration) | Signal inputs | : 4-20 mA , Impedance 0-1kΩ, pulse, relays
Isolated OCT for alarms (on/off with buzzer) |
| ● Repeatability | : ±0.5% of reading | ● Response Time | : < 1 second |
| ● Digital communication | : Isolated RS 485, MODBUS, GPRS/GSM | ● Enclosure | : NEMA 4X (IP65) |
| ● Measurement period | : 0 to 99s | ● Sensor | : IP68(Submersible) |
| ● Ambient Temperature | : -4 ~ 122 °F (-20 ~ 50 °C) | ● Weight | : 4 lb (2 kg) wall mount, 2 lb (1 kg) integral |

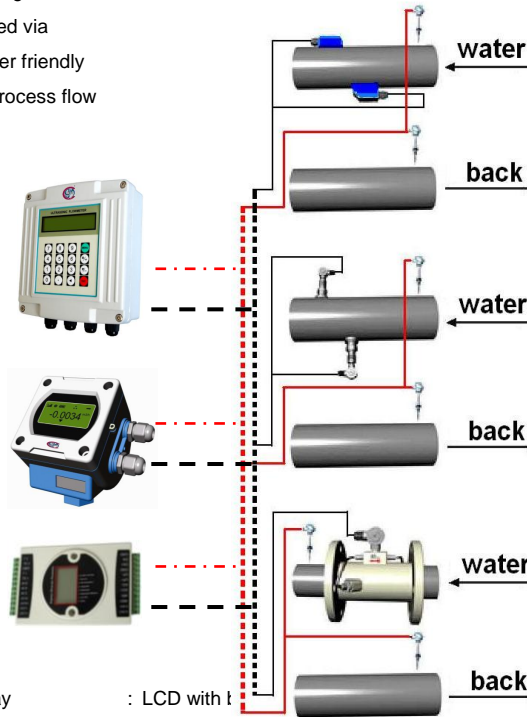

SmartMeasurement

10437 Innovation Drive, Suite 315, Milwaukee, WI 53226, USA

TEL : +1-866-404-5415 FAX : +1-414 -433-1606

TRANSDUCER SPECIFICATION

Standard Transducers

Fluid Temperature : -22 ~ 194 °F (-30 ~ 90 °C)

Accuracy: ±1% of reading

Model	SCS (Small Size)	SCM (Medium Size)	SCL- (Large Size)
Pipe Size	½"-4" (15-100mm)	2"-40" (50-1000mm)	12"-240" (300-6000mm)
A x B x C	1.77" x 0.91" x 0.98"	2.50" x 1.25" x 1.38"	3.86" x 1.77" x 1.92"

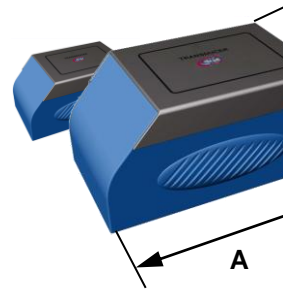

Insertion Transducers

Fluid Temperature : -40 ~ 320 °F (-40 ~ 160 °C)

Accuracy: ±1% of reading

Model	SIS (Standard)	SIL (Large Size)
Pipe Size	3"-40" (80-1000mm)	12"-240" (300-6000mm)



High Temperature Transducers

Fluid Temperature : -22 ~ 320 °F (-30 ~ 160 °C)

Accuracy: ±1% of reading

Model	STS (Small Size)	SHL (Medium Size)
Pipe Size	½"-4" (15-100mm)	2"-40" (50-1000mm)



Inline Type

Fluid Temperature : -40 ~ 320 °F (-40 ~ 160 °C)

Accuracy: 0.5% of reading

Pipe Φ	L	D	D1	Φ×n	D2	f	C
2"	7.87	6.50	4.92	0.71×4	3.90	0.12	0.79
2½"	7.87	7.28	5.71	0.71×4	4.65	0.12	0.79
	8.86	7.87	6.30	0.71×4	5.20	0.12	0.79
	9.84	8.66	7.09	0.71×8	6.14	0.12	0.87
	9.84	9.84	8.27	0.71×8	7.24	0.12	0.87
	11.81	11.22	9.45	0.87×8	8.31	0.12	0.94
	13.78	13.39	11.61	0.87×12	10.47	0.12	0.94
	17.72	15.94	13.98	1.00×12	12.56	0.12	1.02
	19.69	18.11	16.14	1.00×12	14.57	0.16	1.10
	21.65	20.47	18.50	1.00×12	16.89	0.16	1.18
	23.62	22.83	20.67	1.00×16	18.90	0.16	1.26
	27.56	25.20	23.03	1.18×20	21.57	0.16	1.34
	31.50	28.15	25.59	1.30×20	23.98	0.16	1.42
	39.37	33.07	30.31	1.42×20	28.35	0.20	1.50
	43.31	35.83	33.07	1.42×24	31.26	0.20	1.57
	47.24	40.35	37.40	1.54×24	35.47	0.20	1.65
	51.18	44.29	41.34	1.54×28	39.41	0.20	1.73
	55.12	49.41	46.06	1.65×28	43.78	0.20	1.81

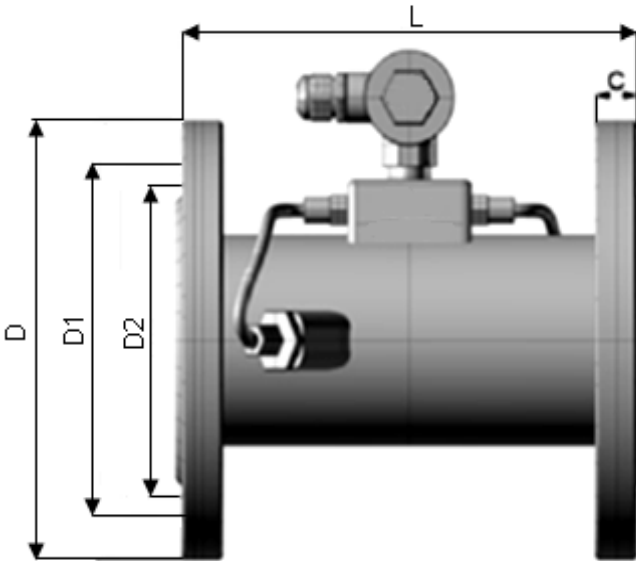

ACCESSORIES

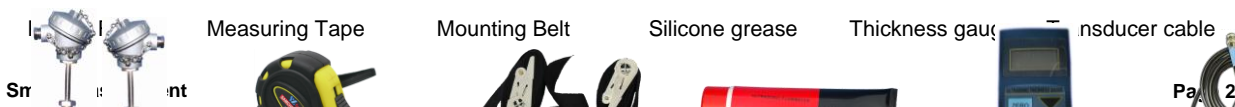

➤ Energy Ultrasonic Flowmeter

• Wall Mount

Size: 7.08" x 6.70" x 2.20"

Material: cast aluminium

Setting data: flow unit, zero, clear total flow, K-factor, date, passwords, linearity factor, etc....

Input: 3 channel 4-20mA analog input, 2 channel resistance signal input

Output: Isolation RS232/RS485 output, MODBUS 2 channel isolation OCT output 1 channel isolation 4-20mA output (two-wire)

Protection: NEMA 4X (IP65)



• Compact

- Display:**
1. status
 2. error time
 3. temperature difference
 4. temperature
 5. energy flow
 6. total flow
 7. flow rate
 8. positive total flow

Size: 3.78" x 3.78" x 5.08"

Input: 3 channel 4-20mA analog input, 2 channel resistance signal input

Output: Isolation RS232/RS485 output, 2 channel isolation OCT output 1 channel isolation 4-20mA output (tow-wire), MODBUS

Protection: IP68

DC Power 3.6V Li battery (for 6 years of operation)



Remote Module

Size: 3.42" x 3.66" x 1.25"

- Display:**
- | | | |
|----------------|------------------------|---------------------------|
| 1. status | 2. error time | 3. temperature difference |
| 4. temperature | 5. energy flow | 6. total energy flow |
| 7. flow rate | 8. positive total flow | |

Input: 3 channel 4-20mA analog input, 2 channel resistance signal input

Output: Isolated RS232/RS485 output 2 channel isolated OCT output 1 channel isolated 4-20mA output (two-wire) Modbus/Meterbus/Fuji Extended Protocol



➤ IN

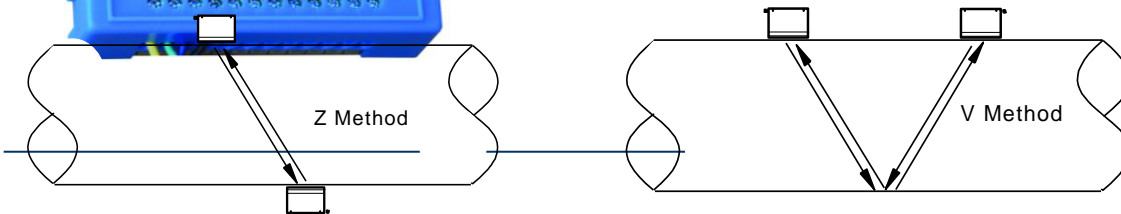

➤ STRAIGHT RUN PIPING REQUIREMENT

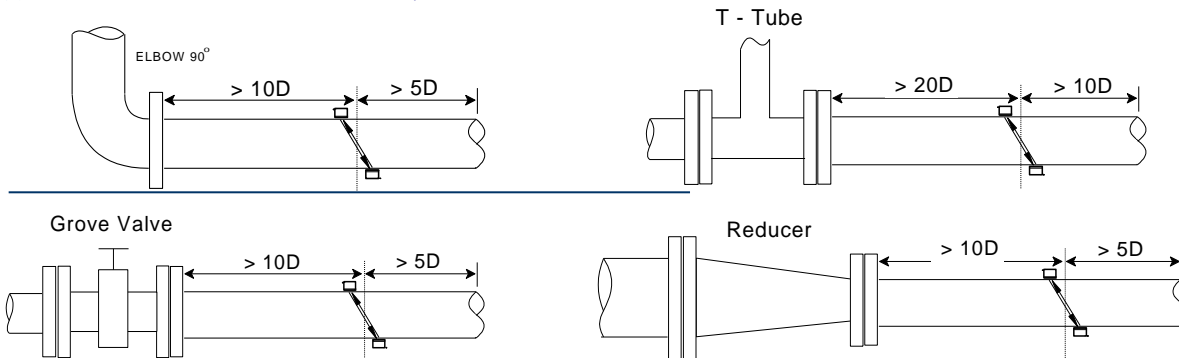



**** Please contact your local SMC application engineer**

You also need to provide the following information:

Type of Fluid	Please provide the name of your fluid, including operating density and viscosity
Line Size	Nominal pipe size and sensor connection type (insertion,clamp, etc..)
Process Pressure and Temperature	We will calibrate your flowmeter as close to your operating conditions as possible
Type of Electronics	Output and installation type (compact, wall mount, panel mount,etc..)
Pipe Material	Please provide the name of your pipe material (Copper, PVC, black iron, etc.)

Model Selection Guide

Alsonic-Energy						
Example 1: Alsonic-EG-CPE-SMCTS-C1-05-AC						
Alsonic-EG-	**	**	**	**	**	Description
Compact-multichannel with display,RS232/RS485,OCT output,4-20mA output	CPE					Flow Meter
Module-Energy, 4-20mA, RTD input, RS-232/RS-485, OCT, 4-20mA output	MUE					
Wall mount with display, mulitchanel input/outputs	WLE					
Pair of PT 100 RTDs		RTD				RTD
Small clamp sensor, ½" - 4" (15 - 100mm)			SCS			Transducers
Medium clamp sensor, 2" - 40" (50 - 1000mm)			SCM			
Large clamp sensor, 12" ~ 240" (300 ~ 6000 mm)			SCL			
High Temp.clamp sensor; -22-320 °F, ½" - 4" (15 - 100 mm)			SHS			
High Temp. clamp sensor; -22-320 °F, 2" - 40" (50 - 1000 mm)			SHL			
Standard insertion sensor			SIS			
Long insertion sensor			SIL			
Inline spool piece please state size in mm			SN-***			
15' (5m), 2 Cables			C1	Signal Cable Length		
30' (10m), 2 Cables			C2			
45' (15m), 2 Cables			C3			
Additional wall mount transmitter				TW	Options	
Additional panel mount transmitter				TP		
Thinkness gague				P1		

