

P9S 90 Series Gauge



Description & Features:

- A general-purpose gauge that is serviceable and pulsation resistant
- 1.5" (40mm) to 3.5" (90mm) dial sizes
- Dampened movement combined with a "flutterless" pointer
- Removable lens
- Zero-adjustment
- CRN registered
- $\pm 2-1-2\%$ accuracy
- 3 year warranty

Applications:

- Compressors, filters, regulators, water pumps, paint sprayers and a variety of other rapid pressure fluctuation applications

Specifications	
Dial	1.5" (40mm), 2" (50mm), 2.5" (63mm), 3.5" (90mm) white aluminum with black and red markings
Case	Steel, painted black
Lens	Acrylic, threaded
Socket	Brass
Connection	1/8" NPT or 1/4" NPT standard
Bourdon Tube	Phosphor bronze
Movement	Brass (flutterless) with zero adjustment
Pointer	Steel, painted black
Welding	Silver alloy
Over-Pressure Limit	25% of full scale value
Working Pressure	Maximum 75% of full scale value
Ambient/Process Temperature	-40°F to 149°F (-40°C to 65°C)
Accuracy	$\pm 2-1-2\%$ ANSI/ASME Grade A

1.5" Bottom Connection

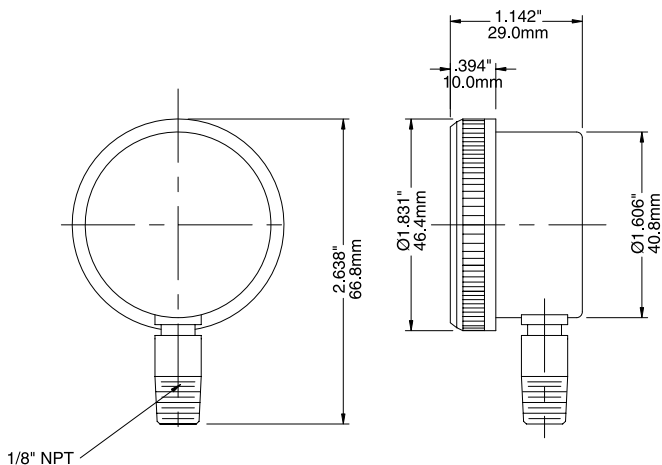

1.5" Back Connection

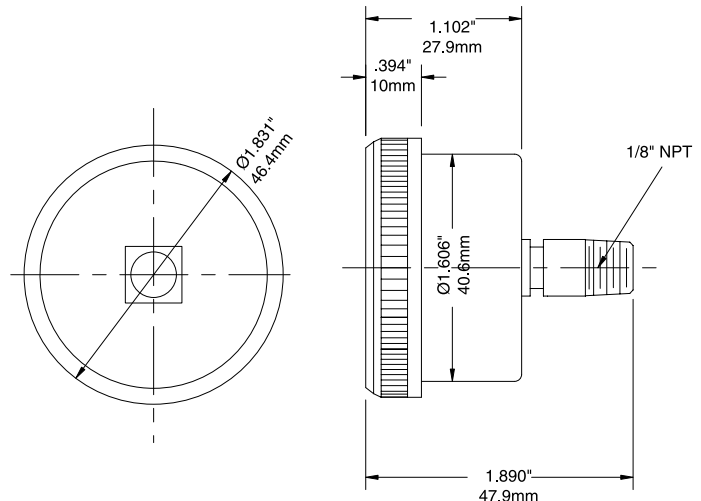

Order Codes (products in bold are normally in stock)

Dial Size	1.5" (40mm)		2" (50mm)				2.5" (63mm)		3.5" (75mm)	
Connection	1/8" Bottom	1/8" Centre Back	1/8" Centre Back	1/4" Centre Back	1/8" Bottom	1/4" Bottom	1/4" Centre Back	1/4" Bottom	1/4" Bottom	1/4" Centre Back
30" Hg. vacuum/kPa	P9S901297	P9S901397	P9S901424	P9S901428	P9S90195	P9S90135	P9S901431	P9S90210	P9S90220	P9S901455
30"/0/15 psi/kPa	-	-	-	-	-	-	-	P9S90152	-	-
30"/0/30 psi/kPa	-	-	-	-	-	-	-	P9S90153	-	-
30"/0/60 psi/kPa	-	-	-	-	-	-	-	P9S90154	-	-
30"/0/100 psi/kPa	-	-	-	-	-	-	-	P9S90155	-	-
0 - 15 psi/kPa	P9S901299	P9S901399	P9S901425	P9S901429	P9S90196	P9S90136	P9S901436	P9S90211	P9S90229	P9S901464
0 - 30 psi/kPa	P9S901300	P9S901400	P9S901402	P9S901403	P9S90206	P9S90199	P9S901437	P9S90212	P9S90221	P9S901456
0 - 60 psi/kPa	P9S901301	P9S901401	P9S901404	P9S901405	P9S90207	P9S90201	P9S901438	P9S90213	P9S90222	P9S901457
0 - 100 psi/kPa	P9S901320	P9S901420	P9S901406	P9S901407	P9S90208	P9S90202	P9S901439	P9S90214	P9S90223	P9S901458
0 - 160 psi/kPa	P9S901321	P9S901421	P9S901408	P9S901409	P9S90197	P9S90203	P9S901440	P9S90215	P9S90224	P9S901459
0 - 200 psi/kPa	P9S901322	P9S901422	P9S901426	P9S901410	P9S90209	P9S90204	P9S901441	P9S90216	P9S90225	P9S901460
0 - 300 psi/kPa	P9S901323	P9S901423	P9S901427	P9S901411	P9S90198	P9S90205	P9S901442	P9S90217	P9S90226	P9S901461
0 - 400 psi/kPa	P9S901324	P9S901443	P9S901445	P9S901447	P9S901449	P9S901451	P9S901453	P9S90219	P9S90227	P9S901462
0 - 600 psi/kPa	P9S901325	P9S901444	P9S901446	P9S901448	P9S901450	P9S901452	P9S901454	P9S90218	P9S90228	P9S901463

2" Bottom Connection

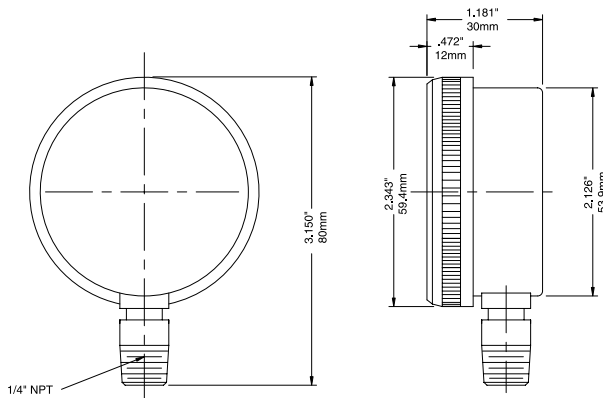

2" Back Connection

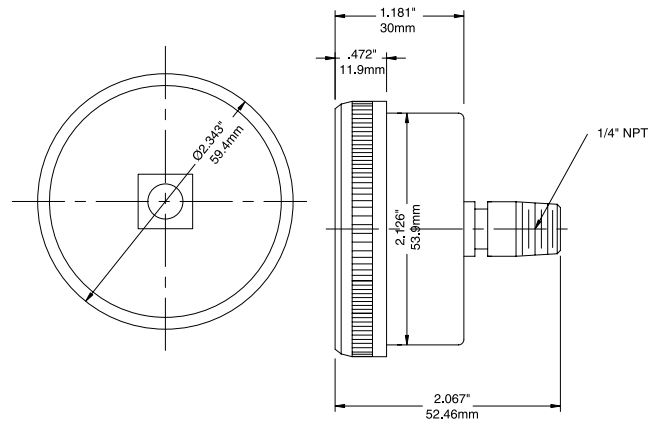

2.5" Bottom Connection

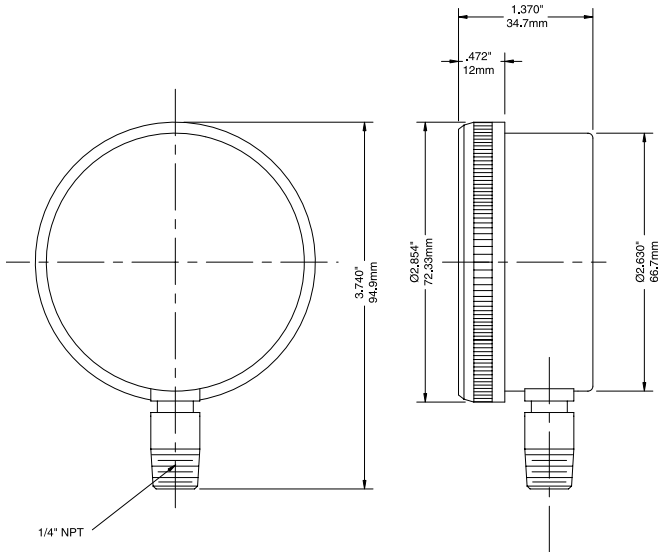

2.5" Back Connection

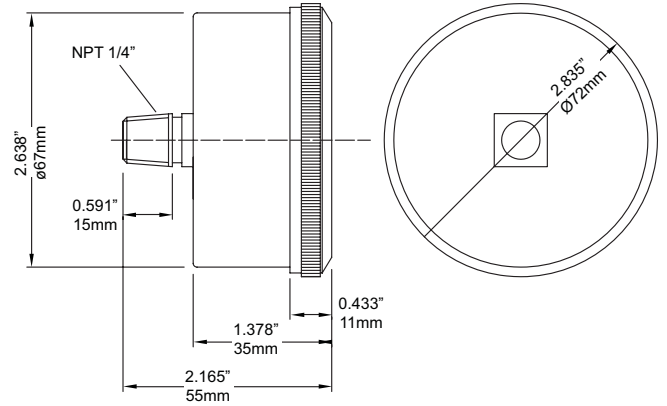

3.5" Bottom Connection

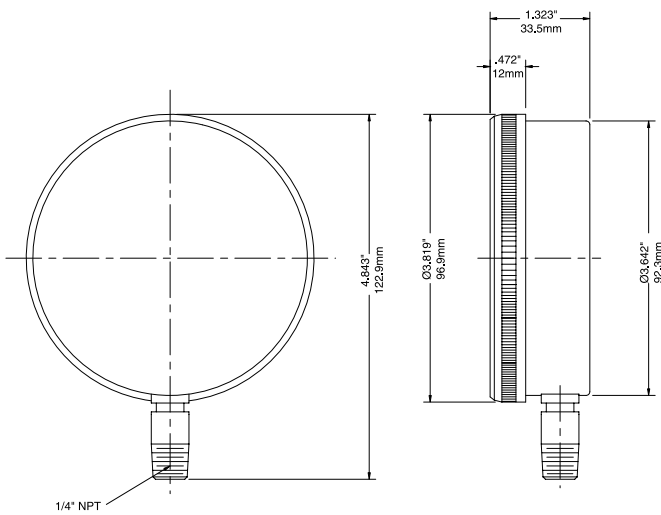

3.5" Back Connection

